

Use of Shuttle Valves

The R-603 is a three input shuttle valve sometimes called a three input "OR". Actuation of V-1 or V-2 or V-3 will give an output at port 6, of V-4, and extend C-1.

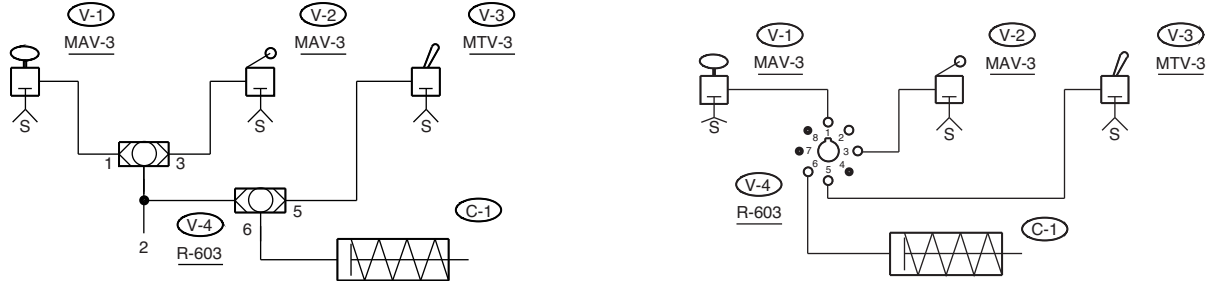

Adjustable 4-Way Pulse

When V-1 is actuated a signal pilots port 4, V-3, extending C-1. The signal is also going to the auxiliary pilot but is delayed by the flow control V-2. When pressure builds up on the pilot, port 6, V-3, it, together with the spring, overcomes the opposite pilot and shifts the valve. C-1 then retracts. V-3 will not cycle again until V-1 is released.

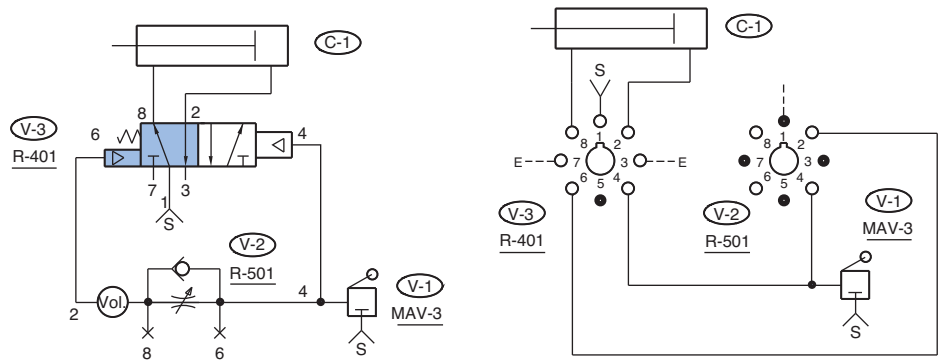

Two-Hand, No-Tie-Down

This circuit provides an output signal to power or pilot a piece of machinery when two push buttons are manually pressed simultaneously. Neither button can be tied down. The output will cease if either button is released. See CM-023 in the Pneumatic Circuit Board section for more details.

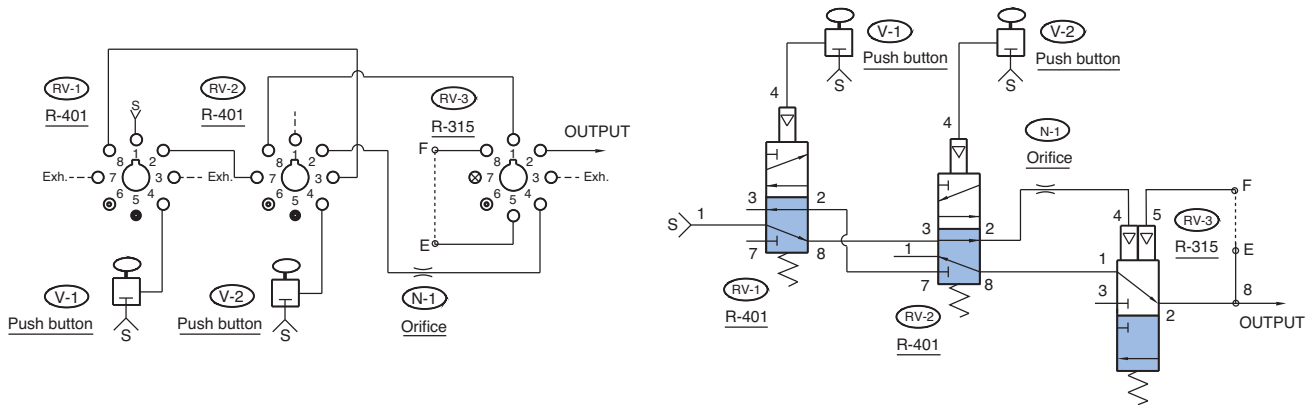

Pilot Signal Priority Lockout

Application of a pilot signal from either push button will pneumatically lock out the output of the other push button to eliminate the possibility of a dual output.

